



Precise Detection  
for an Uncertain World

# The XT250™ Material Identification System



**Fast**

**Accurate**

**Cost-Effective  
Authentication**

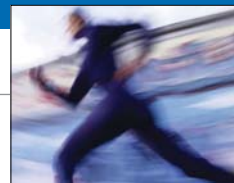

## The XT250 Material Identification System

XStream Systems, Inc. offers patented systems based on Energy Dispersive X-Ray Diffraction (EDXRD), a highly sensitive and accurate technology previously available only in expensive, high-end systems used by major laboratories.

The self-contained XT250™ System conclusively identifies materials based on their crystalline structure. With the push of a button, the XT250 System's Material Recognition Software Engine (MRSE) can identify or authenticate materials as wide ranging as drugs, dry chemicals, food products, explosives and more. The unit's easy loading test chamber will accommodate sample containers or sealed pharmaceutical bottles of multiple sizes without any complex preparation, providing great versatility.

### Applications

Material Detection  
Authentication/Verification  
Quality Control  
Dry Chemical Identification  
Research & Development

### Features

Superior Sample Penetration  
Easy to Use  
Scans Crystalline Structure  
Identifies Materials Quickly  
Customizable Software

### Material Recognition

Drugs  
Dry Chemicals  
Food Products  
Explosives  
Customized MRSEs

# XT250™ System Specifications

Electrical Power:	(US) 115V 60Hz 5A (max) (EU) 230V 50Hz 2.5A (max) 600 W (max)
Operating Temperature:	10°–35°C
Archival Storage:	5,000 sample records
X-Ray Source:	80kV Tungsten sealed tube, air cooled (40 W)
Detector:	Cadmium Telluride (CdTe), thermoelectrically cooled
Weight:	400 lbs
Display:	800 x 600 resolution
Built-in Processor:	Intel® Pentium® 4
Operating System:	Windows® XP
Hard Drive:	160 GBytes
External Printer:	Optional

### Controls:

Power Key Switch  
 12" LCD Rear-Mount Touchmonitor  
 Customizable Display with:  
*Operation Buttons:* START, CANCEL,  
 CONFIRM, PRINT & OPEN  
*Menu Buttons:* MAIN, MATERIALS,  
 CONFIG & SYSTEM

### External Interfaces:

Remote Management  
 One (1) 10/100 Ethernet  
 One (1) 1,000 Ethernet  
 Two (2) USB 2.0 Type A Interfaces  
 AGP VGA Monitor Port

## Dimensions

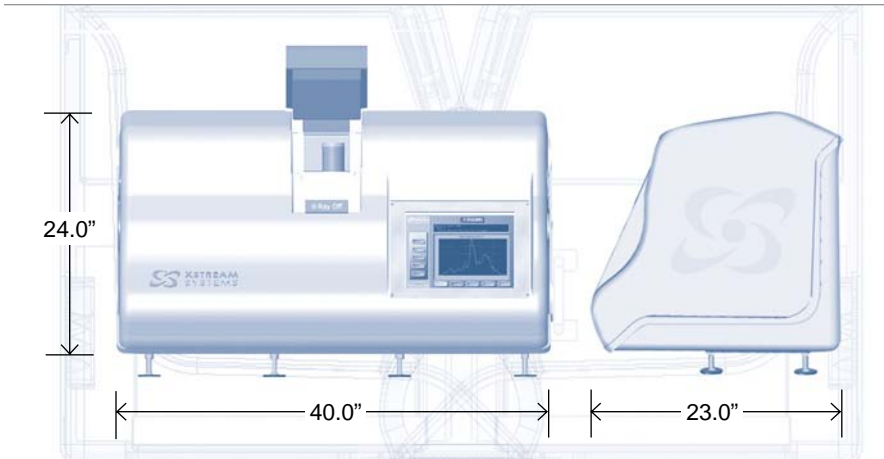

**XSTREAM**  
SYSTEMS



Toll Free: **1-800-597-1191**

Washington DC Area Office: 21445 Beaumeade Circle, Ashburn, VA 20147

Corporate Headquarters: 10305 102nd Terrace, Ste. 101, Sebastian, FL 32958 (772) 646-6200 fax: (772) 589-4622

[www.xstreamsystems.net](http://www.xstreamsystems.net)